



SequoiaEtc

Strength. Reliability. Integrity.

Sequoia Etc provides award winning service and leads the industry in shaping the way PTC Solutions are utilized.

December 2007

Wildfire 3.0 Tips and Tricks

Hidden Config.pro option (must type)
allow_round_all set to yes

Gives you two additional options in the Round Sets Dashboard (All Convex and All Concave)

Use SHIFT to remove edges from selection

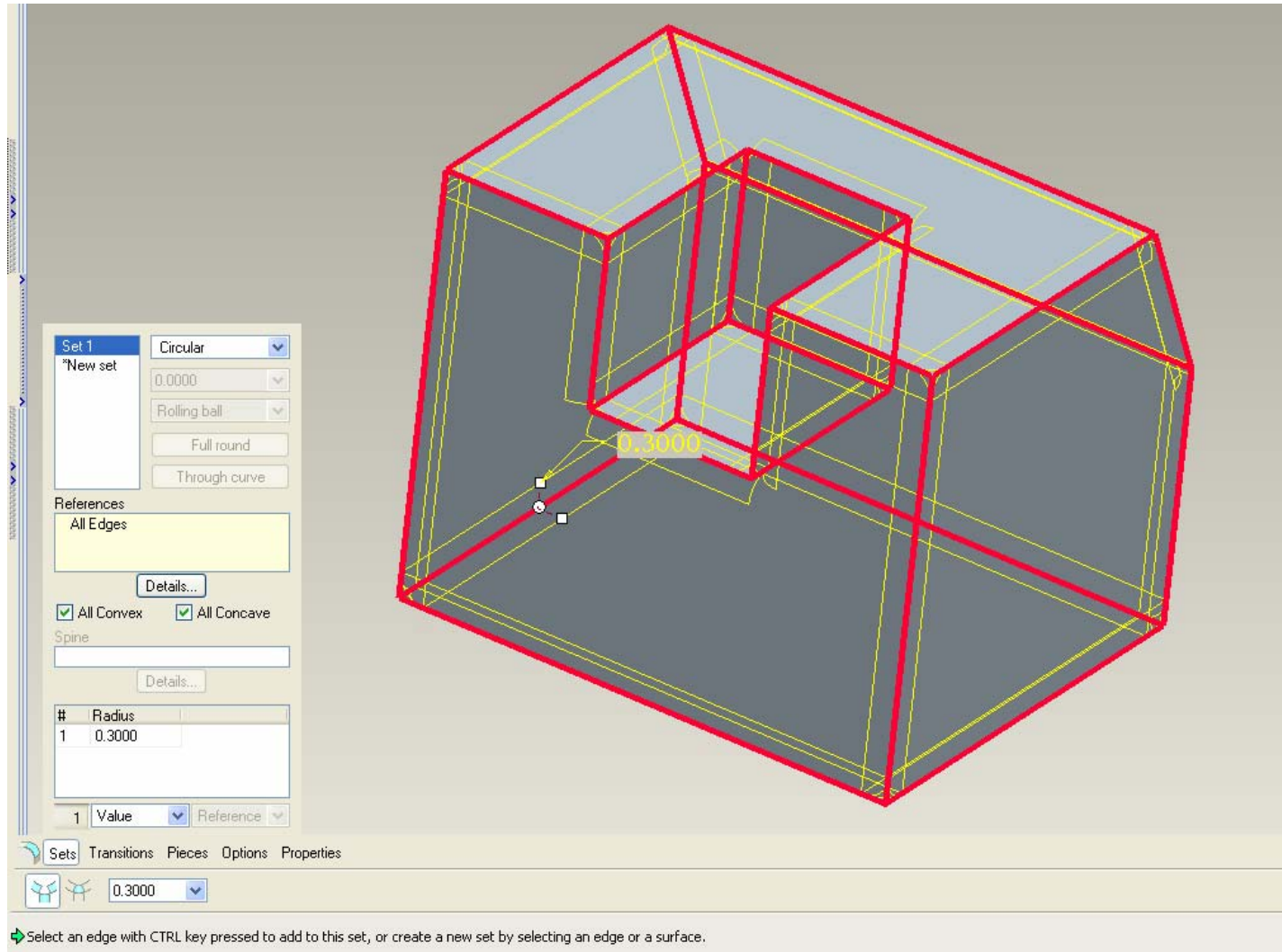

Config.pro option show_shaded_edges set to yes
or View>Display Settings>Model Display

If you do not always want to show shaded edges, create two mapkeys. The first mapkey turns on the shaded edges and the second turns them off so you can quickly toggle the display.

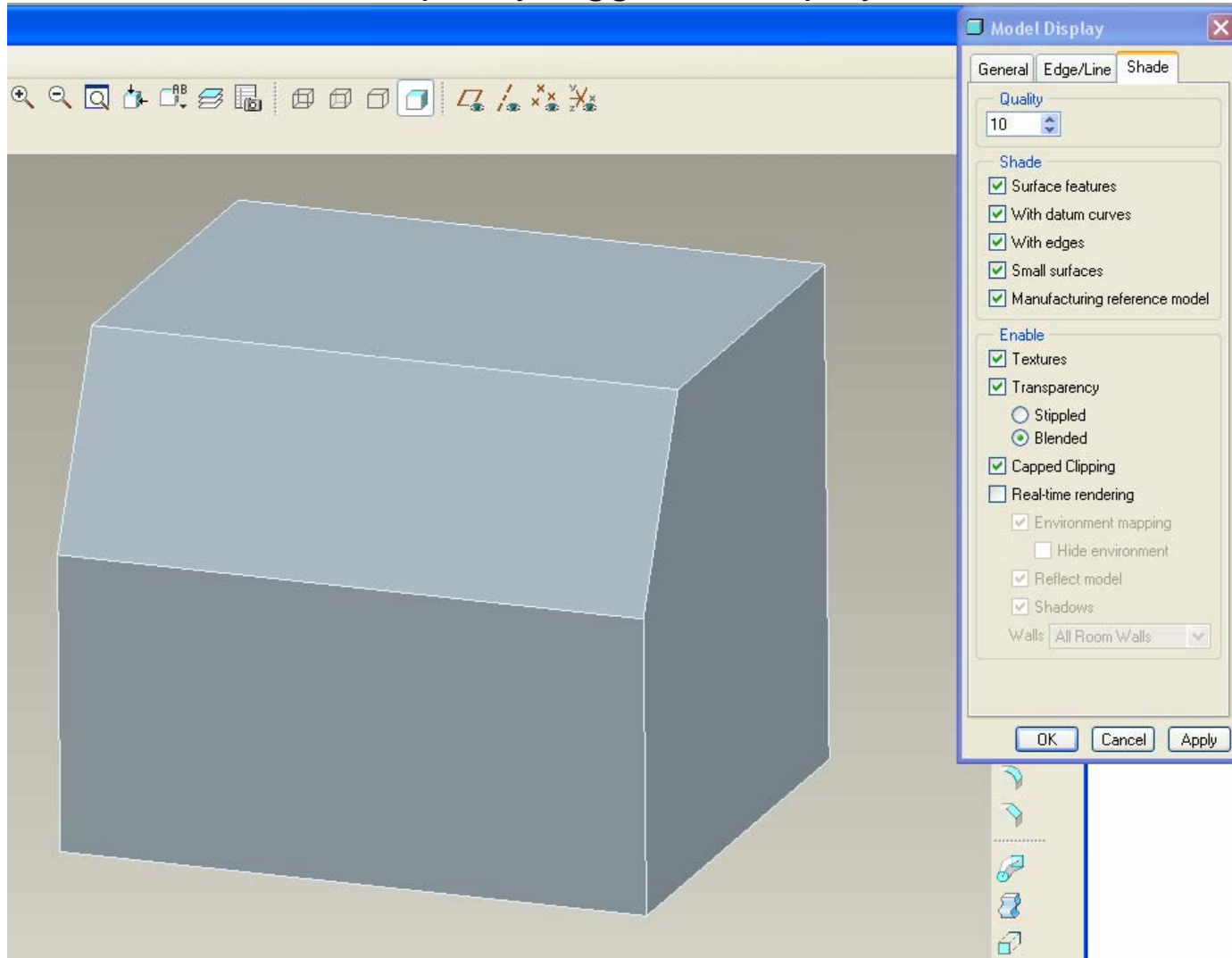

How to show material differentiation with Color
Make the part one color. Select surfaces and make them another color.
This should occur prior to any additional features (after the base feature)
(shown with edges displayed)

